

## For IN-LINE & SANDMASTER Series Separators

- Provides proper & professional support for LAKOS Separators
- Available with both machine and log bolts for desired installation
- Durable steel construction

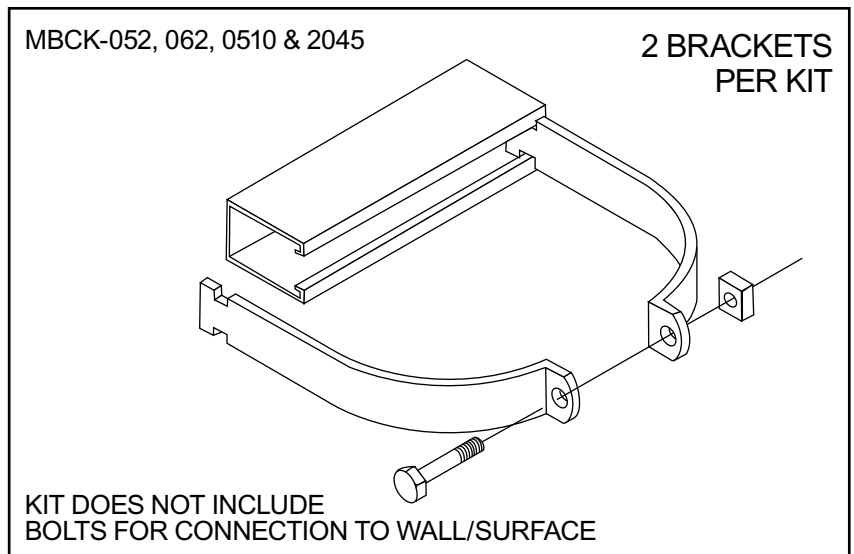
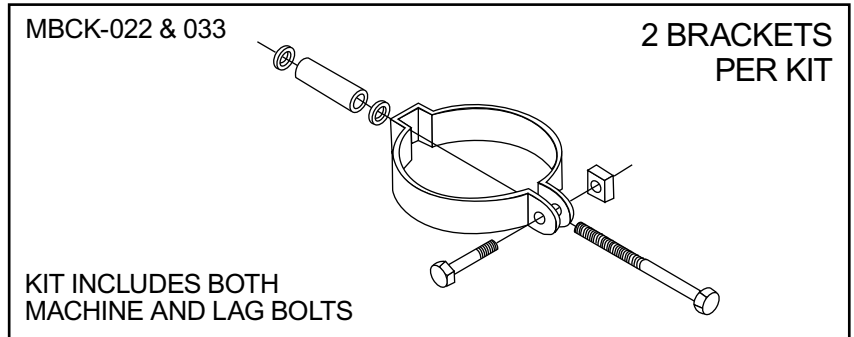
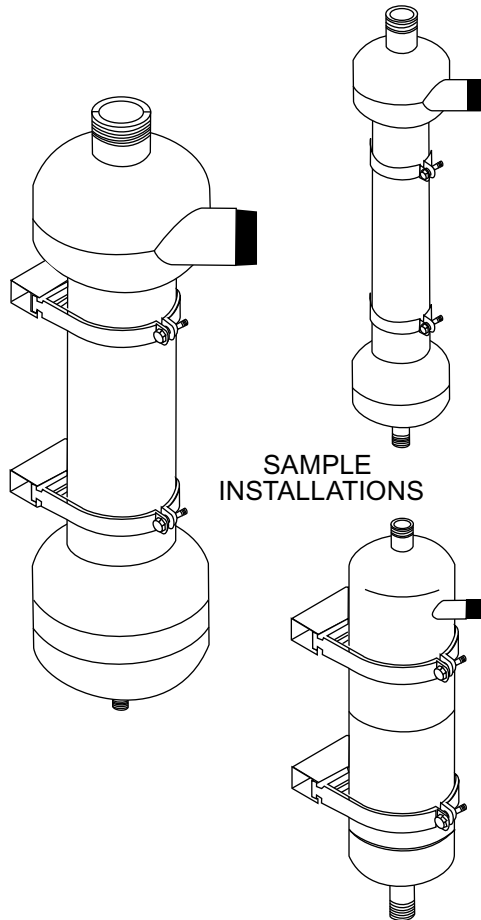

### GENERAL SPECIFICATIONS

SEPARATOR MODEL	RECOMMENDED BRACKET	WEIGHT	
		lbs	kg
ILB/ILS-0037	MBCK-011	0.87	.39
ILB/ILS-0050	MBCK-015	1.02	.46
ILB/ILS-0075	MBCK-022	1	.4
ILB/ILS-0100 ILB/ILS-0125 ILB/ILS-0150	MBCK-033	2	.9
ILB/ILS-0200 ILB/ILS-0250	MBCK-052	5	2.3
ILB/ILS-0300	MBCK-062	5	2.3
H20/SMP-05 H20/SMP-10	MBCK-0510	4	.18
H20/SMP-20 H20/SMP-30 H20/SMP-45	MBCK-2045	5	2.3

**For IN-LINE Series Separators**

- Attachable legs for model ILB/ILS Separator
- Two-part clamp-on with tripod legs

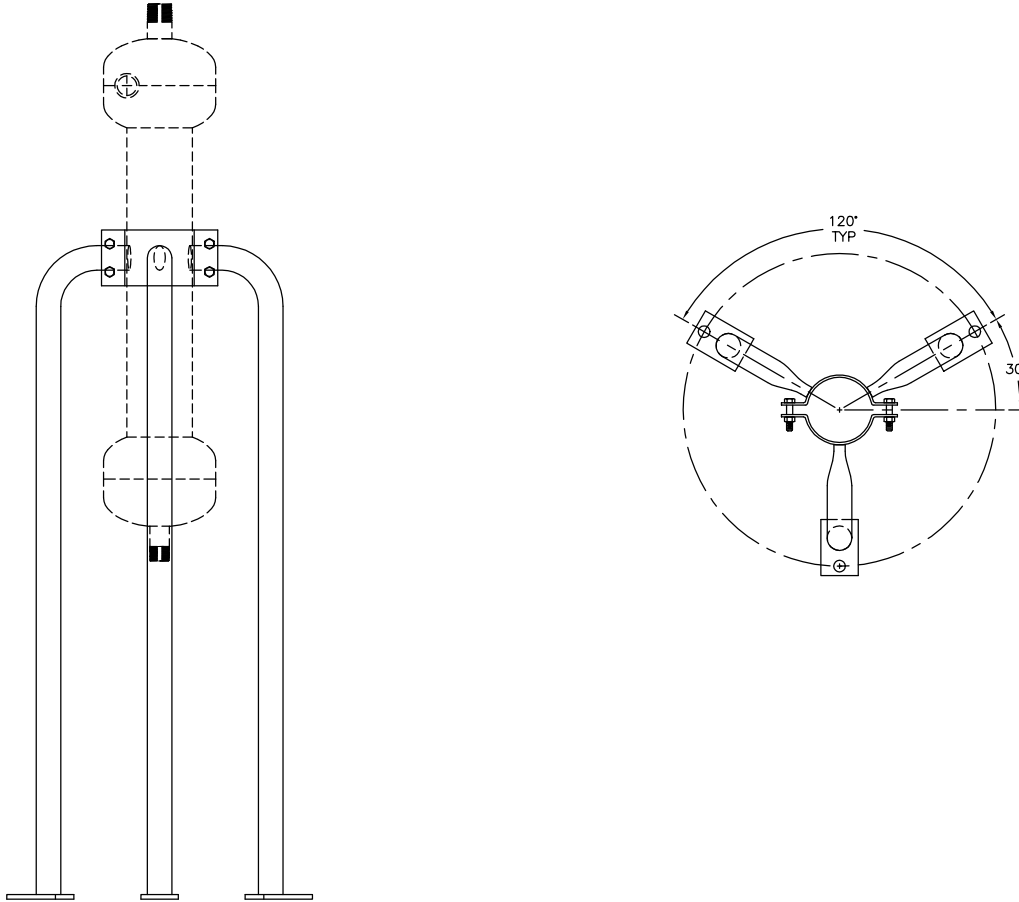

**GENERAL SPECIFICATIONS**

SEPARATOR MODEL	RECOMMENDED LEG	WEIGHT	
		lbs	kg
ILB/ILS-0037	ILL-0038	25	11
ILB/ILS-0050	ILL-0050	25	11
ILB/ILS-0075	ILL-0075	25	11
ILB/ILS-0150	ILL-1015	25	11
ILB/ILS-0250	ILL-2025	25	11
ILB/ILS-0300	ILL-3099	25	11